



# 1/10TH SCALE HIGH PERFORMANCE RACING KIT

## Owner's Manual



Thank you for selecting this HPI racing car! This kit is designed to be easy to build and uses top quality parts for durability and performance. The staff at HPI Racing tries hard to make everything easy to build and trouble-free. If you have any problem with this kit, give us a call and we will do our best to help you.

## Tools

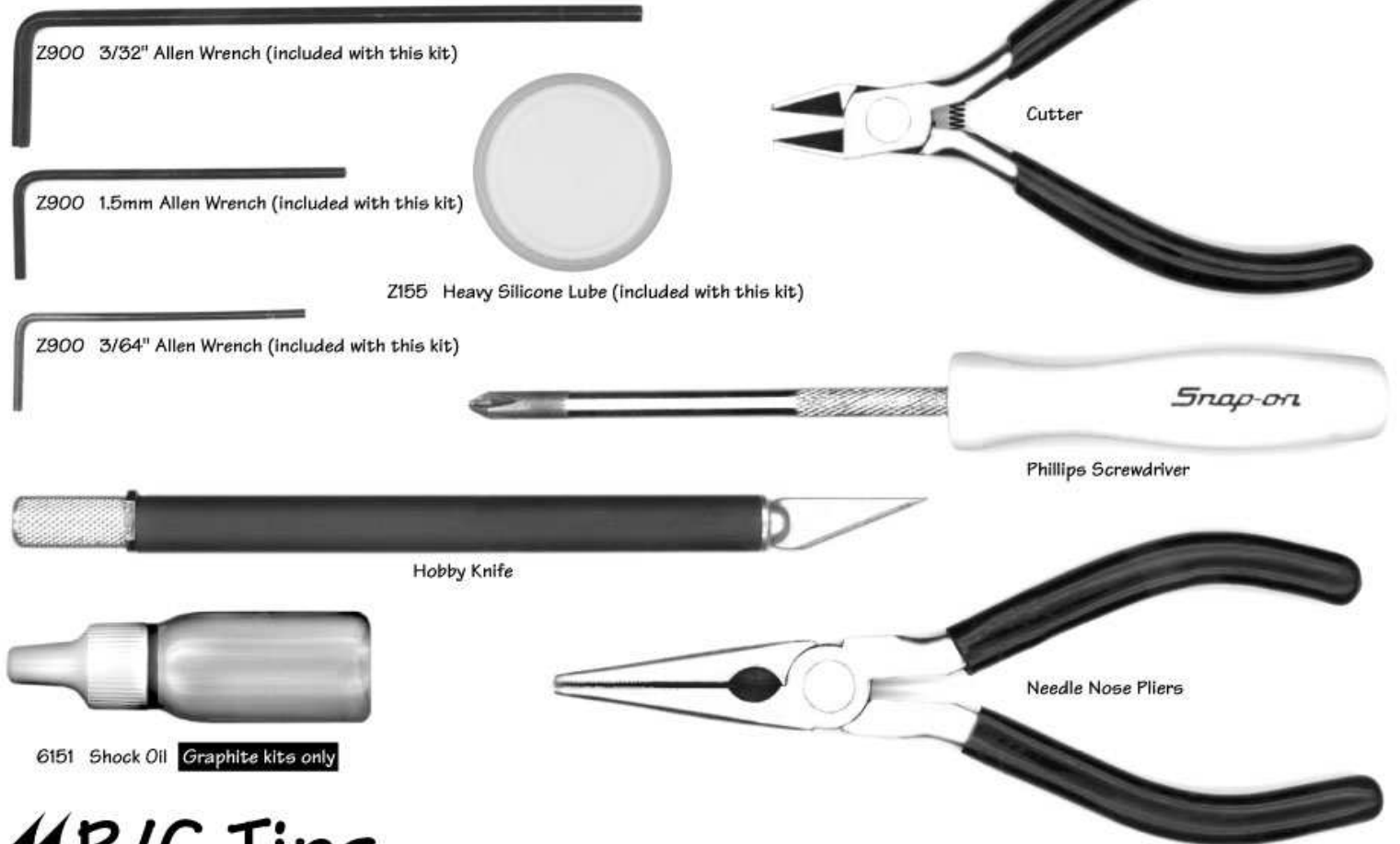

## R/C Tips

R/C cars are fun to drive, but be aware that driving them in the wrong places can cause serious damage. Never drive near real cars, animals, or people that are unaware that an R/C car is being driven.



When learning to drive, go to an area that has no obstacles that can damage your car if you have a crash. Stay away from curbs, parked cars, poles, etc. Always wear shoes when driving!

### Important basics...

- Build this kit in an area out of reach from children. Tools, parts, and liquids can be dangerous!
- Follow the operating instructions for the radio equipment at all times.
- Always turn on the transmitter before you turn on the car.
- Keep the wheels of the car off of the ground when checking the operation of the radio equipment.
- Always turn off the radio system and unplug the battery pack when not using the car.
- Follow the operating instructions for the Ni-Cd batteries and Ni-Cd battery charger at all times.
- Insulate any exposed electrical wiring with heat shrink tubing to prevent dangerous short-circuits.

- A001 Lower Arm (R) x 1
- A001 Lower Arm (L) x 1
- A002 Socket Arm x 2



- A005 Pivot Ball x 4

**1** Use needle-nose pliers to press balls into both lower arms and both socket arms. The surface of the pliers should be flat to prevent damage to the balls. The flange of all of the balls should point toward the front axle.

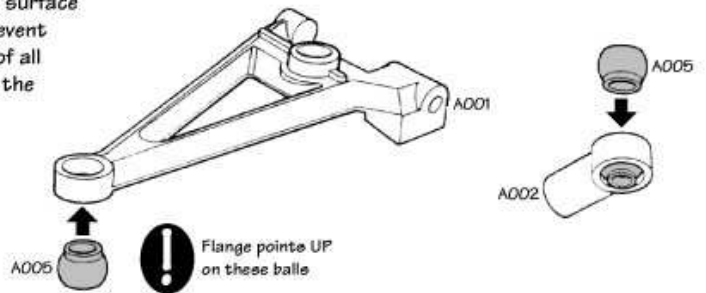

- A009 Joint Pin (A) x 2

**2** Use needle-nose pliers to press the joint pins into both lower arms.

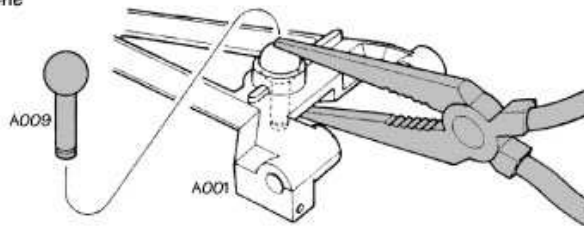

- A001 Lower Arm Mount x 1



- A006 Pin x 2



- Z200 E Clip x 4

**3** Install lower arms to lower arm mount with pins and secure with E clips.

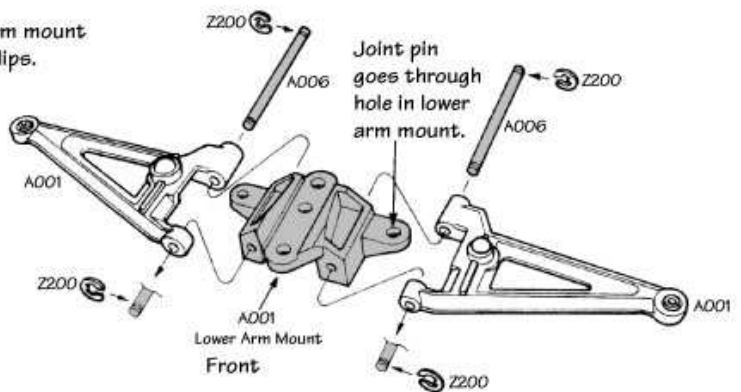

- A012 Front Spring (E) x 2



- Z203 Washer x 2



- Z200 E Clip x 2

**4** Install washer, spring, and secure with E clip. Compress spring with needle nose pliers if E clip does not slide on easily.

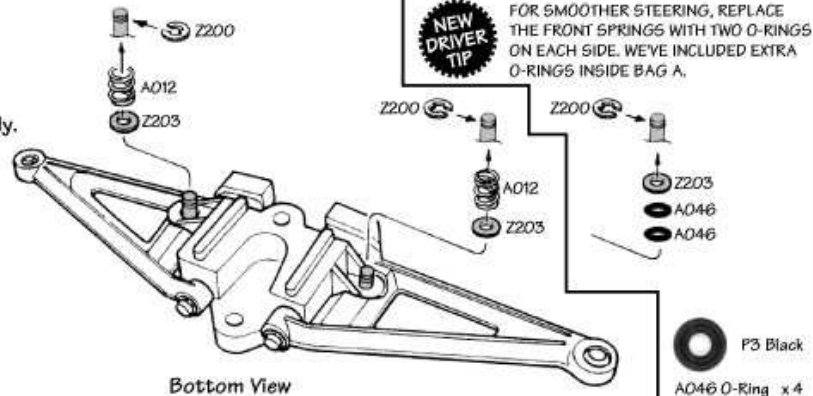

- A001 Upper Arm x 2



- A010 Turnbuckle (A) x 2

**5** Screw turnbuckles into both upper arms. The turnbuckles are not symmetrical, so install them as shown.

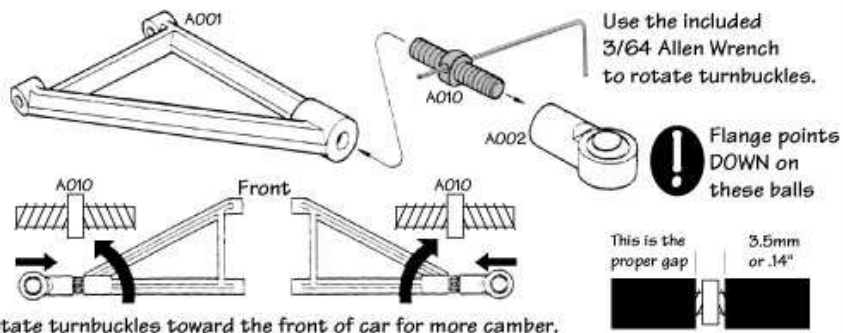

Rotate turnbuckles toward the front of car for more camber.

A001 Upper Arm Mount x 1

A008 Upper Arm Pin x 2

(Located on plastic tree, see page 12)  
A003 Castor Shims x 4

6

Connect upper arms to upper arm mount using upper arm pins. Castor shims should be installed as shown.

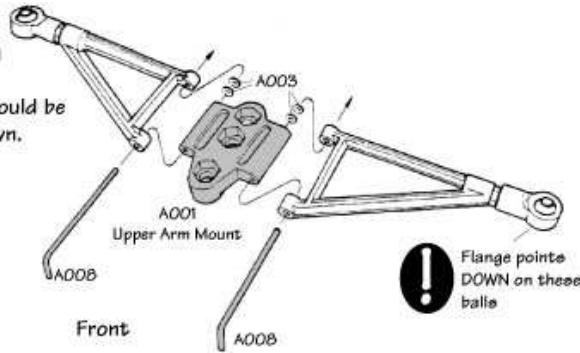

**NEW DRIVER TIP**

THE CAR WILL BE MORE STABLE AND EASIER TO DRIVE WHEN THE CASTOR SHIMS ARE INSTALLED AS SHOWN.

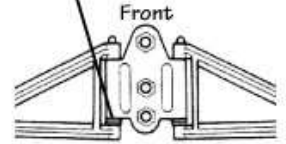

A002 Steering Arms x 2

A011 Front Axle (A) x 2

Z126 Ball End x 2

4-40  
Z127 Lock Nut x 2

7

Press front axles into steering arms. Install ball ends and lock nuts as shown, balls must point up. A 3/16" socket or a Tamiya wrench will make installation easier.

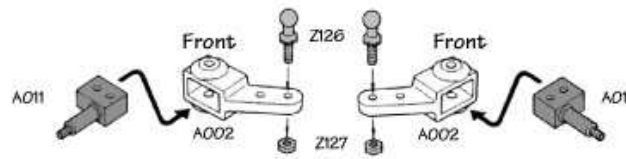

**NEW DRIVER TIP**

CHOOSE MILD STEERING

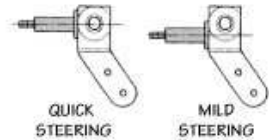

A022 Chassis (Graphite) x 1  
A074 Chassis (FRP) x 1

(Located on plastic tree, see page 12)  
A003 King Pin Spacer x 10

29.5mm  
A007 Pin x 2

1/8"  
Z200 E Clip x 4

M4 x 25  
Z201 Flat Head Screw x 1

M4  
Z202 Nut x 1

8

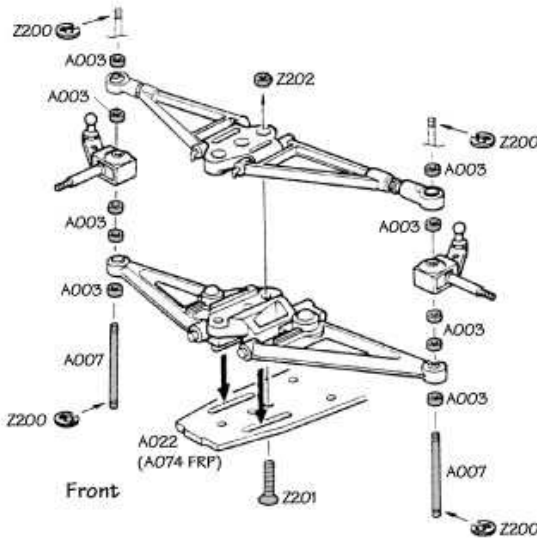

**TAMIYA**  
COMPATIBLE!  
OUR FRONT SUSPENSION BOLTS DIRECTLY TO F103 TYPE CHASSIS

Connect upper and lower arms to chassis. Install king pins and steering arms as shown. Note that ball ends must point up and toward the back of the car. The king pin spacers will give the proper ride height when installed as shown, but can be rearranged to adjust ride height if necessary.

Z120 Servo Saver x 1

Z126 Ball End x 2

Servo Saver Screw x 1

9

Choose the adaptor that fits your servo.

Press the adaptor into the servo saver.

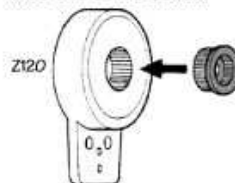

Remove the servo ears so that it can be mounted standing up.

This screw is included with servo saver.

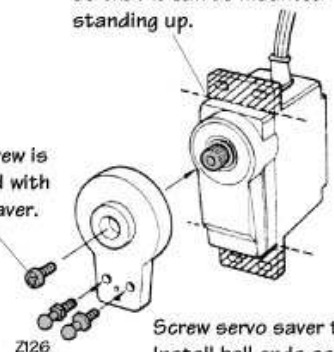

Screw servo saver to servo. Install ball ends as shown.

- A002 Servo Mount A x 1
- A002 Servo Mount B x 1

- Z125 Ball Cup x 4

- Z140 Turnbuckle (B) x 2

- 4-40 x 3/8" Z206 Flat Head Screw x 4

- 6163 Servo Tape x 1

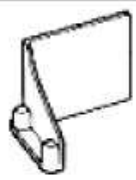

## 10

Thread the ball cups onto turnbuckles as shown, noting the direction of the threads.

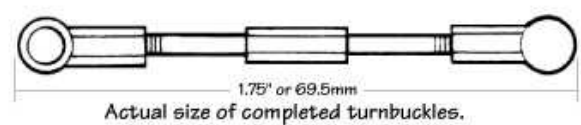

Install the servo using servo tape. Position the servo so that the ball ends attached to the servo saver are 1/8" from the front suspension's lower pins. Snap the turnbuckles to the steering arms and servo saver. When installed as shown, rotating turnbuckles toward the front of the car will give more toe-in.

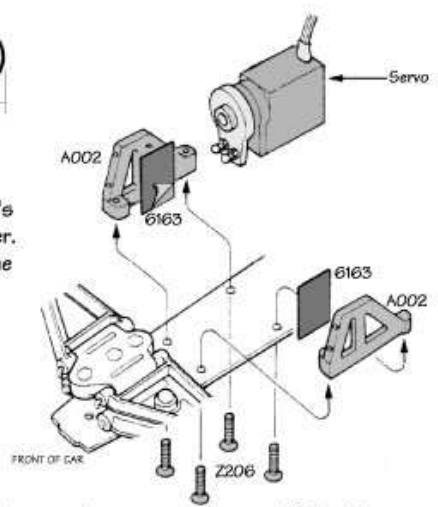

The servo saver should be cut here so it does not hit the servo mount. Cut off the threads of the ball ends on the back of the servo saver to allow more clearance.

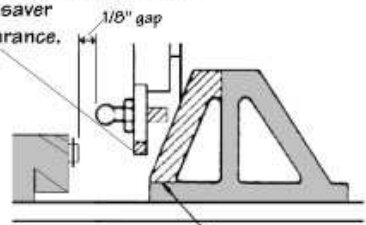

When using large servos it may be necessary to cut this section.

Both dots on the inside for wide servos.

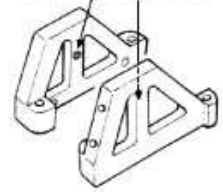

Both dots on the outside for narrow servos.

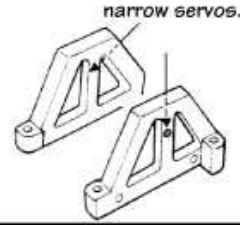

- A004 Roll Socket (R) x 1
- A004 Roll Socket (L) x 1
- A004 Pivot Socket (B Thin) x 1
- A004 Pivot Socket (A) x 1
- A004 Pivot Socket (C) x 2
- A004 Pivot Socket (D) x 2
- A013 Roll Brace (Graphite) x 1
- A032 Roll Brace (FRP) x 1
- A014 Spring Brace x 1
- A017 Roll Tower x 1

- A016 Pivot Ball (A) x 3

- A018 Roll Spring (A) x 2

- 4-40 x 3/8" Z206 Flat Head Screw x 3

- M2 x 10 Z209 Flat Head Screw x 4

- 2-56 x 5/16" Z210 Button Head Screw x 10

- M2 Z211 Nut x 4

- 2-56 x 3/16" Z221 Button Head Screw x 4

## 11

Assemble as shown. Note that the center pivot socket has rounded sides and is thinner than the outer pivot sockets. The pivot balls have been squared at the top so they can be gripped with pliers.

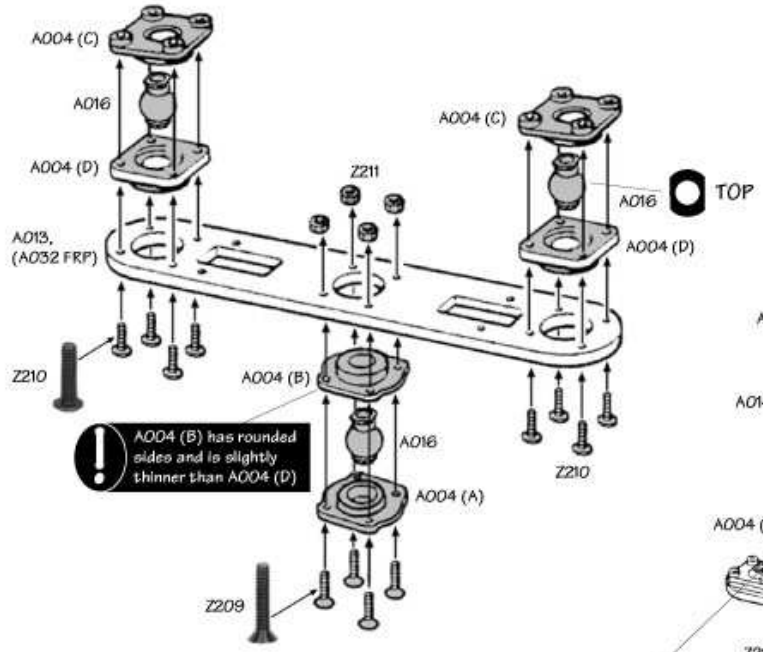





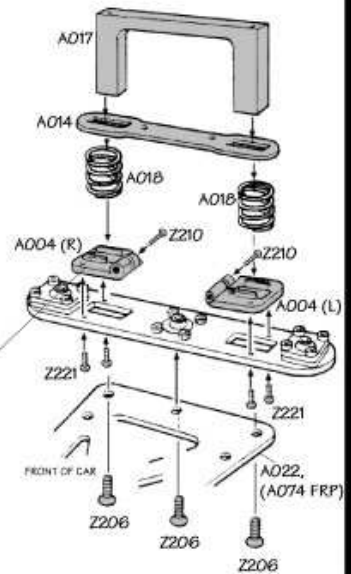





A004 (B) has rounded sides and is slightly thinner than A004 (D)

Insert the roll brace into the roll sockets before tightening the screws (Z221 and Z210). After tightening the screws, the roll sockets should slide smoothly. If the roll sockets are too tight, use a file to remove a small amount of graphite (or fiberglass) from the rectangular holes in the roll brace to provide more clearance for the roll sockets. Assemble as shown, check again for smooth movement.



12

- A023 Chassis Brace (Graphite) x 1
- A075 Chassis Brace (FRP) x 1
- A001 Rear Body Mount x 2
- A026 Antenna Mount x 1

	P3 Black	
	AO46 O-Ring	x 2
	18.5mm AO15 Aluminum Tube	x 1
	25mm AO24 Aluminum Tube	x 3
	5mm AO27 Aluminum Tube	x 1
	4-40 x 3/8"	x 4
	4-40 x 3/16"	x 6
	M3 x 12 <b>METRIC!!</b>	x 1
	6121 Hood Pin	x 4
	4-40 x 5/16"	x 2

Assemble chassis brace as shown. Note that the screw that goes into the antenna mount is longer than the others and has metric threads.



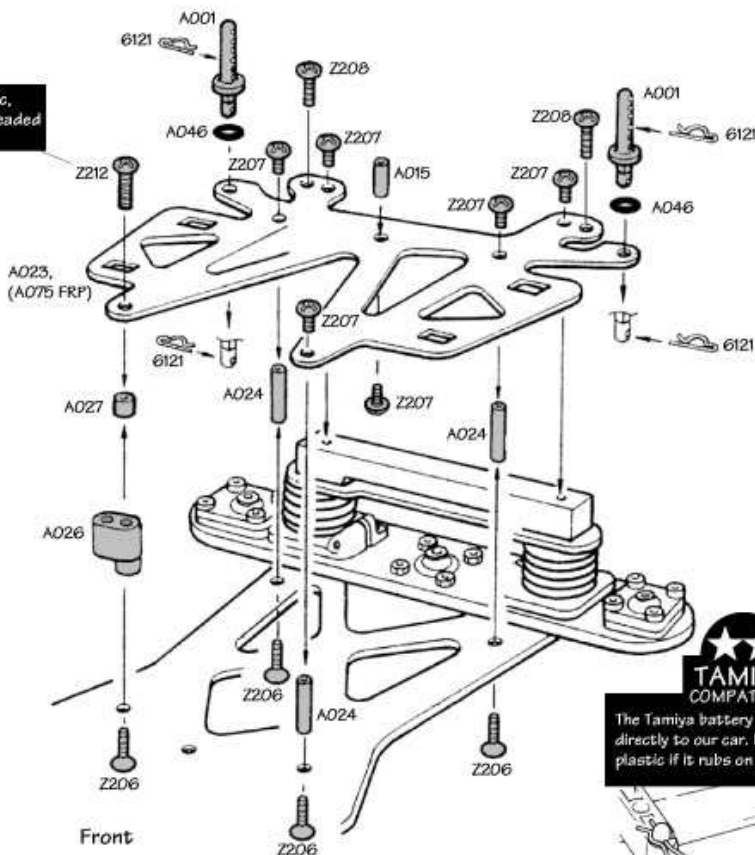



**!** This screw is metric, don't use it on threaded aluminum tubes!



**TAMIYA COMPATIBLE!**  
The Tamiya battery holder will bolt directly to our car. File away some plastic if it rubs on the roll brace.

13

- A029 Lower Brace (Graphite) x 1
- A062 Lower Brace (FRP) x 1
- A030 Motor Mount x 1
- A031 Left Bulkhead x 1
- A033 Height Adaptor #1 x 2
- A034 Height Adaptor #2 x 2

	1/4" x 3/8" Flanged	
	B010 Bearing (rear)	x 2
	8-32 x 1/2" Green	x 4
	4-40 x 1/4"	x 1
	4-40 x 3/8"	x 2
	A035 Spacer (C) Aluminum Cone	x 2

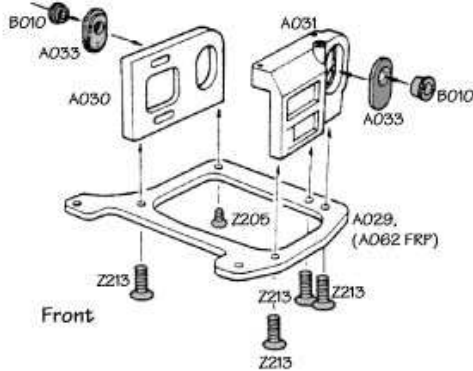

Assemble rear pod as shown. The ride height of the car can be adjusted using Height Adaptors #1 or #2. When using the tires provided in this kit, Height Adaptor #1 should be used in the position shown.

Attach rear pod to chassis as shown. A small drop of temporary thread-lock will prevent the screws from vibrating loose.

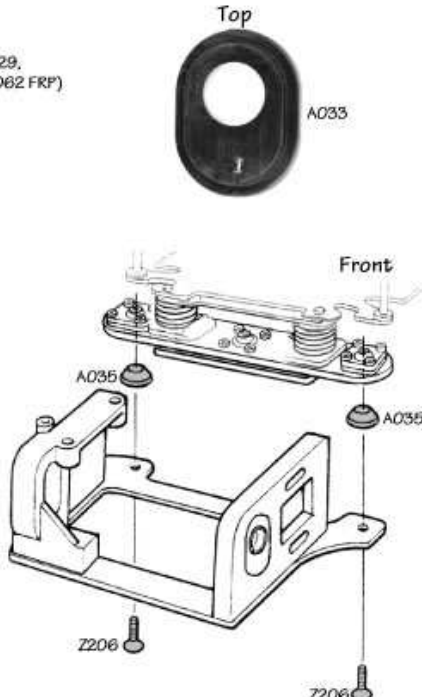

- A004 Dampener Washer x 2
- A028 Upper Brace (Graphite) x 1
- A063 Upper Brace (FRP) x 1



-  A019 Dampener Spring x 2

-  P5 Black A020 O-Ring x 1

-  4-40 x 1/4" Z205 Flat Head Screw x 1

-  Countersunk 6075 Washer x 1





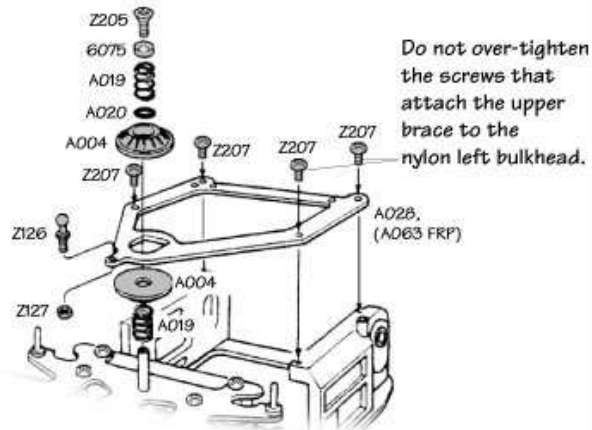

**14** Assemble as shown. A small amount of heavy silicone diff lube should be applied to the surface of the dampener washers and O-rings.

-  4-40 x 3/16" Z207 Button Head Screw x 4
-  Z126 Ball End x 1
-  4/40 Z127 Lock Nut x 1



- Z005 Shock Set (oil filled) x 1

- Z006 Shock Parts (A) x 1





-  E-Clip (E2)
-  Piston
-  E-Clip (E2)
-  Retainer
-  Washer (P3 Red)
-  O-Ring
-  Washer (Thick)
-  O-Ring (P3 Red)

-  Shock Shaft
-  Rubber Washer

- Z007 Spring Cap/Perch x 1

-  Spring Cap
-  Spring Perch
-  Perch Screw

- Z010 Friction Shock (FRP kits) x 1

-  Shock Cap
-  Shock Body
-  Shock Spring
-  Shock Shaft

-  Z125 Ball Cup x 1

-  25mm A024 Aluminum Tube x 1

-  Z012 Shock Spacer x 1

-  4-40 x 3/8" Z206 Flat Head Screw x 2

**15** Assemble shock shaft as shown. Note that the E-clips are smaller than standard 1/8" size.

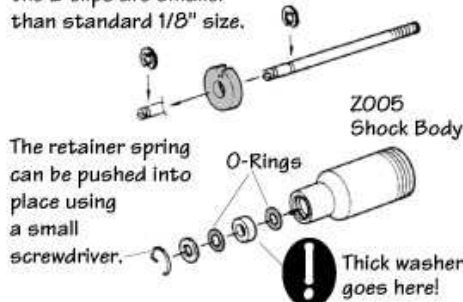

**FRP kits**  
Insert shock shaft as shown.



Put a drop of heavy silicone lube inside the shock body.

**16** Insert shaft into shock body.



**FRP kits**  
Install spring and screw on cap and ball cup.

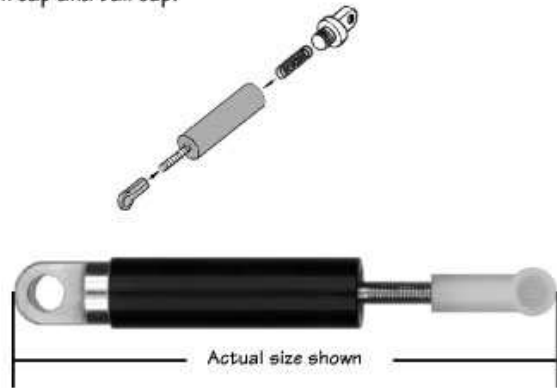

Final assembly should look like this. The ball cup can be used to adjust the ride-height of the chassis. Unscrewing the ball cup will increase the ride-height.

**17** Connect shock to chassis as shown.

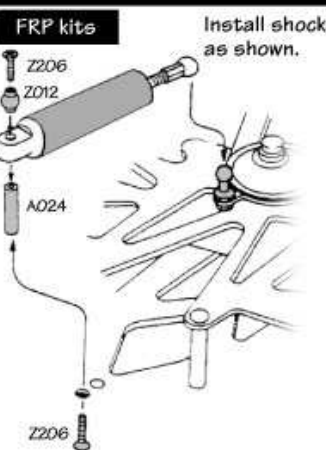
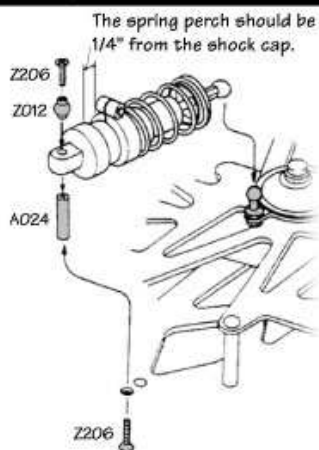
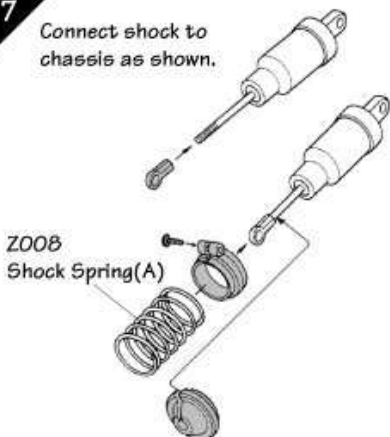

- 6694 Spur Gear (94 T) x 1
- 6501 Diff Ball x 8
- A037 Rear Axle (Graphite) x 1
- A057 Rear Axle (steel) x 1
- A038 Diff Hub (R) x 1
- A040 Drive Ring x 2

18

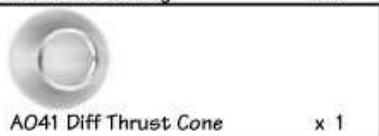

AO41 Diff Thrust Cone x 1

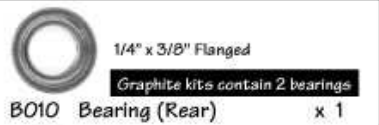

B010 Bearing (Rear) x 1



Z218 Nylon Locknut x 1

A039 Axle Hub (L) x 1

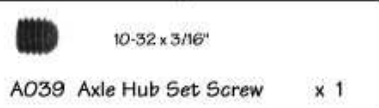

A039 Axle Hub Set Screw x 1



A042 Axle Spacer x 3



Z214 Button Head Screw x 2



6625 Pinion Gear (25 T) x 1



6625 Set Screw x 1

3502 Front Wheel x 2

5103 Green Donut (front) x 2

6225 Front Tire Tape (narrow) x 4

3512 Rear Wheel x 2

5113 Green Donut (rear) x 2

6224 Rear Tire Tape (wide) x 4

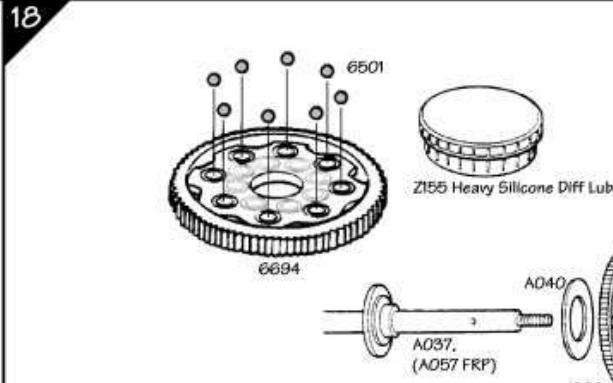

Press diff balls into outer holes of spur gear. Apply a small amount of diff lube to each ball. Assemble differential as shown. Adjust the diff slippage by tightening or loosening the nylon locknut.

- A041 Spring Washer x 3
- A003 Flanged Bushing x 1

To test diff, hold both wheels and try to spin the spur gear with your thumb. The spur gear should be difficult to rotate when properly adjusted.

19

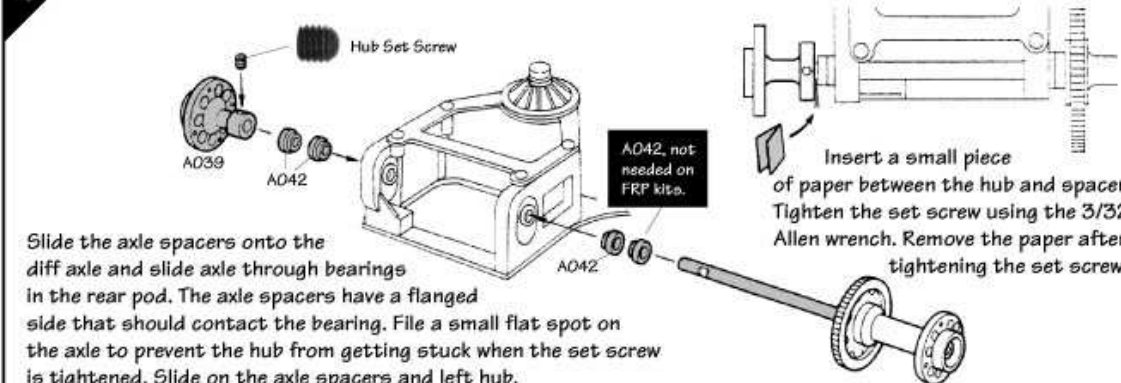

Slide the axle spacers onto the diff axle and slide axle through bearings in the rear pod. The axle spacers have a flanged side that should contact the bearing. File a small flat spot on the axle to prevent the hub from getting stuck when the set screw is tightened. Slide on the axle spacers and left hub.

Insert a small piece of paper between the hub and spacer. Tighten the set screw using the 3/32 Allen wrench. Remove the paper after tightening the set screw.

20

Insert an .05 type motor through the lower pod and secure using the metric motor screws. Slide the pinion gear onto the motor shaft so that the teeth fully contact the spur gear teeth.

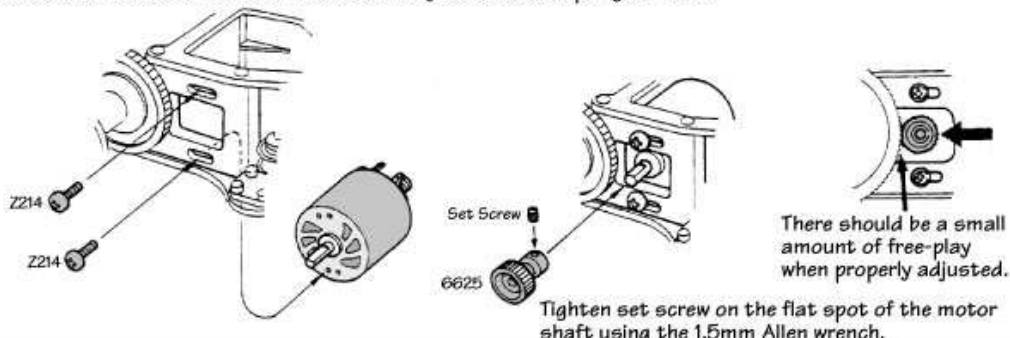

There should be a small amount of free-play when properly adjusted.

Tighten set screw on the flat spot of the motor shaft using the 1.5mm Allen wrench.

21

Remove the paper side of tire tape and stick tire tape to wheels. Leave the plastic side on the tape and slide the tires onto the wheels.

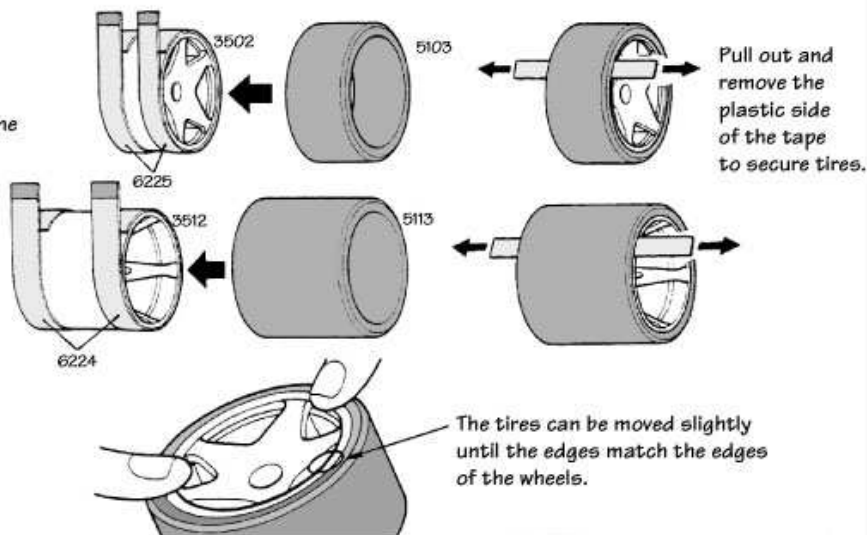

Pull out and remove the plastic side of the tape to secure tires.

The tires can be moved slightly until the edges match the edges of the wheels.

A003 3/16" Flanged Bushing x 4

Graphite kits only

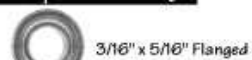

3/16" x 5/16" Flanged

B005 Bearing (Front) x 4



5-40 Black

Z220 Nylon Locknut x 2

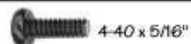

Z208 Button Head Screw x 8

22

Press the bearings or bushings into the front wheels. Slide front wheels onto steering axles and tighten nut. Bushings should be oiled frequently. The wheel should spin freely.

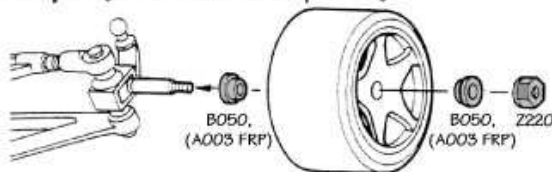

Press the rear wheels onto the rear hubs. Secure with wheel screws.

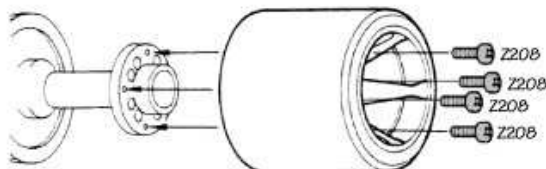

A043 Front Wing x 1

A001 Front Body Mount x 1

A043 Rear Wing x 1

A043 Rear Wing (B) x 1



M4 x 25

Z201 Flat Head Screw x 2



M4

Z202 Nut x 2



Z208 Button Head Screw x 1



Z204 Flat Head Screw x 4

23

Assemble as shown.

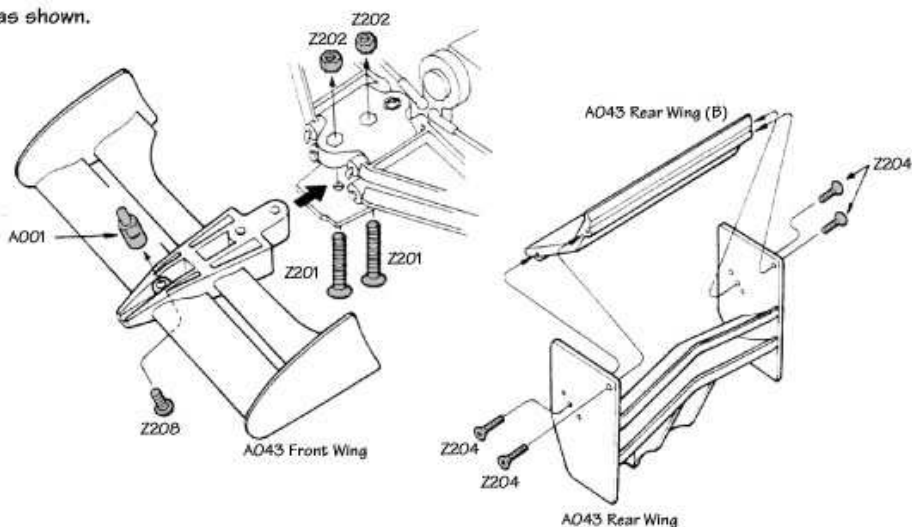

A043 Wing Mount x 1



4-40 x 3/8"

Z206 Flat Head Screw x 2



4-40 x 5/16"

Z208 Button Head Screw x 2

24

Assemble as shown.

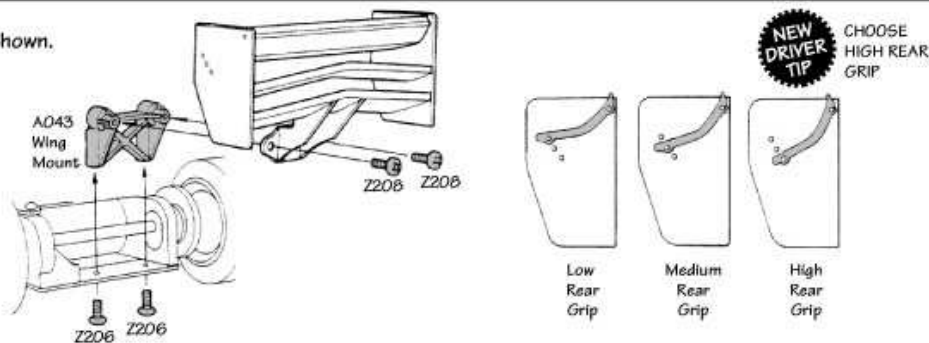

**NEW DRIVER TIP**  
CHOOSE HIGH REAR GRIP

Z150 Antenna Tube x 1

Z150 Antenna Tube Cap x 1

25

Press antenna tube into the antenna mount. If the antenna tube is too loose, pinch it with pliers.

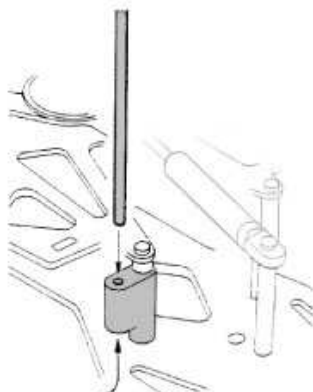

The receiver antenna can be inserted through the bottom hole.

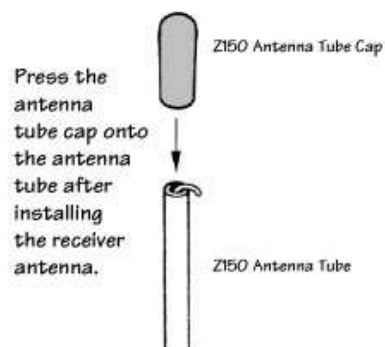

Press the antenna tube cap onto the antenna tube after installing the receiver antenna.

7016 Lexan Turning Vane x 1

26

Mount the radio equipment. You may find it necessary to position your radio equipment in alternate positions so that the body fits. Note that if the supplied lexan "turning vane" is used, it must be attached to the chassis before the radio equipment is installed.

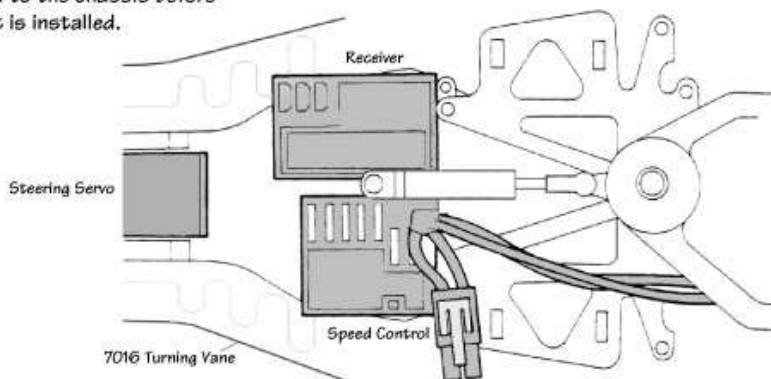

6228 Nylon Tie Wrap x 2

27

Install a battery pack using the nylon tie wraps. Tighten the tie wraps using pliers. The tie wraps can be loosened by pressing the release tab. A Tamiya battery holder system can also be mounted to our chassis using the existing chassis holes.

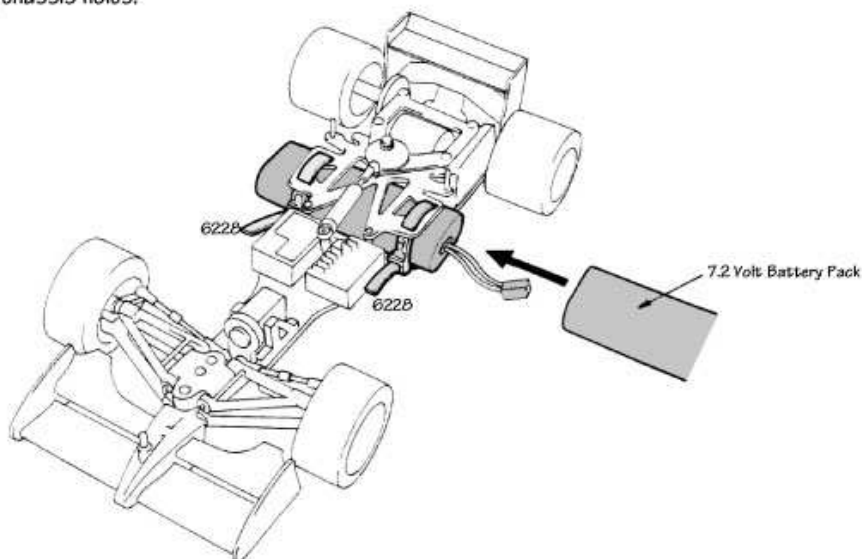

7016 M Type Body x 1

28

Paint the F1 body as desired. The body has a protective plastic coating on the outside that has been marked with the proper hole positions and trim lines. Remove the plastic coating and install body as shown.

6121 Hood Pin x 3

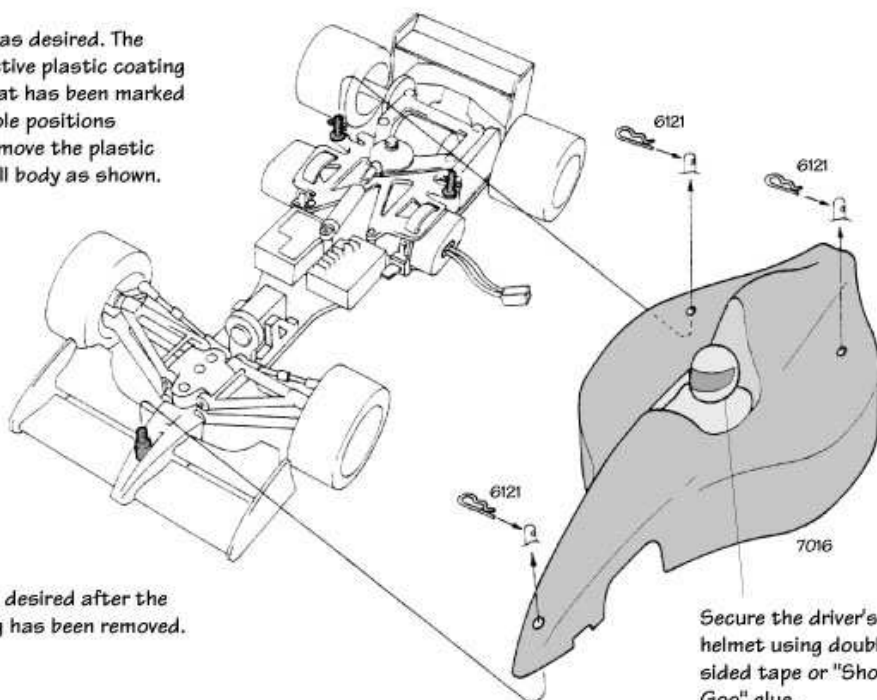

Decal the body as desired after the protective coating has been removed.

Secure the driver's helmet using double sided tape or "Shoe Goo" glue.

## RACING TIPS

The HPI F1 car was designed to have high grip on most surfaces. We have built in several ways to help adjust the handling of the car for maximum performance. The following information will help you tune the car to the track conditions. Of course, the best way to learn how to adjust the car is to practice and test as much as possible!

### SLIPPERY TRACK CONDITIONS

- Adjust rear wing to "High Rear Grip" position, see page 9.
- Adjust front suspension to 6° castor position, see diagram below and page 4.
- Set the front axle to "Mild Steering" position, see page 4.
- Use O-rings instead of springs in the front suspension, see page 3.
- Use a mild motor, large pinion gear, and an ESC with a current limiter set for smooth throttle response.
- Check turning radius in both directions, adjust steering radius to smallest amount that allows you to steer around sharpest corner.
- Try a harder front tire compound. Use tire traction sauce on rear tires. Make sure rear tires are in good condition.
- Make sure car is "tweaked" flat, see diagram below.

### BUMPY TRACK CONDITIONS (Use the same settings as for slippery conditions, plus the following settings)

- Adjust ride height for more ground clearance to prevent chassis from "bottoming out" over bumps, see page 4 and 6.
- Use very light silicone lube on the dampener washers, see page 7.
- Install an oil filled shock with light shock oil (20 to 30 weight) and use a soft shock spring.

### VERY HIGH GRIP TRACK CONDITIONS

- Adjust rear wing to "Low Rear Grip" position, see page 9.
- Adjust front suspension to 2° castor position, see diagram below and page 4.
- Set the front axle to "Quick Steering" position, see page 4.
- Use extra amount of silicone lube or heavier silicone lube on dampener washers, see page 7.
- Lower the chassis by using small tires front and rear, or adjusting the front kingpin spacers and rear height adaptors.

### TUNING THE FRONT SUSPENSION

The HPI F1 car has a unique double-wishbone front suspension that allows you to make adjustments that will help the car perform better.

#### CASTOR

The castor of the suspension can be adjusted using the supplied castor shims. The goal of adjusting the castor is to make the car easy to drive. When built with both shims toward the rear of the car, the steering will be mild and the car will return to a very stable straight line. When built with both shims toward the front of the car, the steering will be more sensitive to small steering movements.

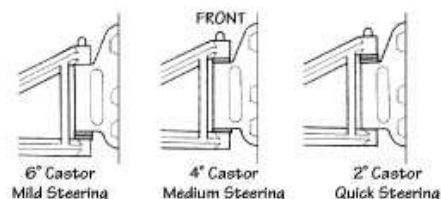

#### CAMBER

The camber of the suspension can be adjusted by rotating the turnbuckles. The goal of adjusting the camber is to adjust the suspension to provide even wear across the entire front tire. The turnbuckles have asymmetrical threads that allow you to make easy changes to the settings without removing any components. When built as described in Step 5, rotating the turnbuckles toward the front of the car will give more camber. Since foam tires have a small amount of deflection during hard cornering, we recommend a small amount of negative camber for proper tire wear. If more negative camber is needed to make the tires wear flat, rotate the turnbuckles a small amount toward the front of the car.

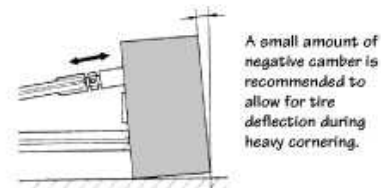

### TUNING THE REAR SUSPENSION

The HPI F1 car features a Triple-Pivot rear suspension that allows you to make adjustments that will help the car perform better.

#### TWEEKING THE CAR FLAT

The "tweek" of the car can be adjusted. The goal of adjusting the tweek is to provide equal weight on the rear tires so that the car corners equally when turned to the left and right. To test the tweek of the rear tires, place the car on a flat surface and use a small screwdriver to lift the center of the lower brace. When the tires lift off the ground, they should both lift at the same time. If one tire lifts later than the other, then that tire has more weight being applied to it, making the car unbalanced. Use the tweek screws to adjust the pressure applied to the spring brace until both rear tires lift at the same time. Rotating the tweek screw in the clockwise direction makes that tire heavier.

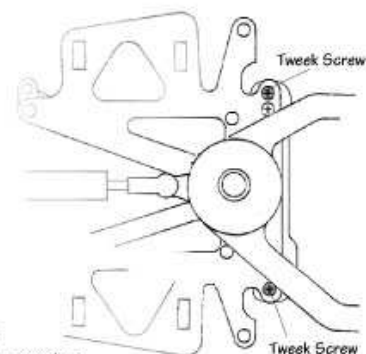

#### ADJUSTING THE RIDE HEIGHT OF THE CHASSIS

The shock can be used to adjust the ride height of the chassis. The goal of adjusting the ride height is to make the chassis flat from the front of the car to the rear of the car. To check the ride height, place the car (with battery, radio, and motor installed) on a flat surface.

**FRP KITS:** If the chassis droops in the middle of the car, unscrew the ball cup on the shock shaft until the chassis is flat. If extra ground clearance is needed on bumpy tracks, adjust the ball cup so that the chassis raises slightly in the center.

**GRAPHITE KITS:** Loosen the perch screw and slide the spring perch toward the rear of the car until the chassis is flat, then tighten the perch screw.

**A001 F1 Front Suspension**

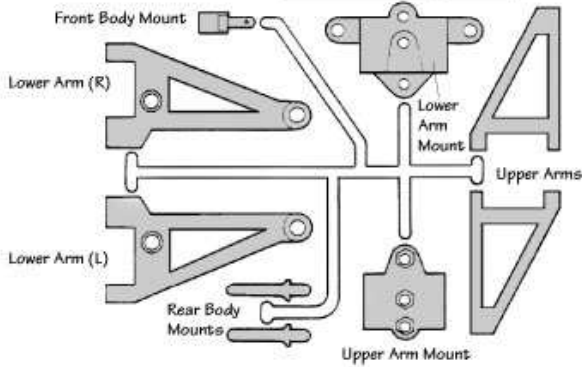

**A002 Steering Parts**

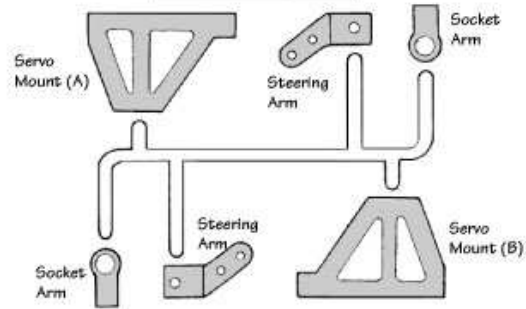

1/4" x 3/8" Flanged Bushings  
(Not needed in Graphite kit)

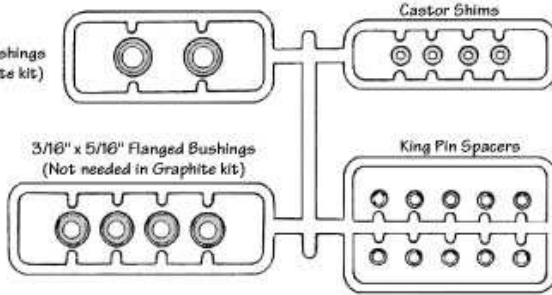

**A003 Shim/Bushing Set**

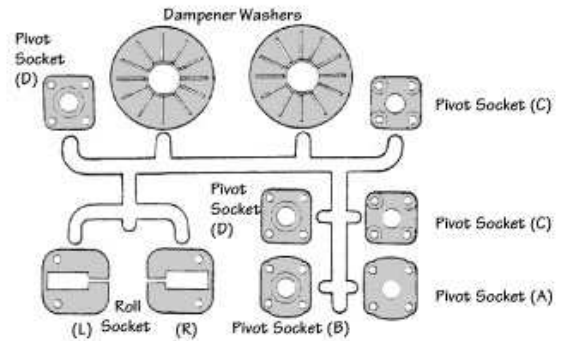

**A004 Rear Suspension**

# HPI RACING PARTS

Part #	QTY	Name	Retail Price	Part #	QTY	Name	Retail Price
3502	2	1/10 STAR ON ROAD RIMS BLACK (F)	\$ 6.00	A037	1	REAR AXLE (GRAPHITE)	\$ 22.50
3512	2	1/10 STAR ONROAD RIMS BLACK (R)	6.00	A038	1	DIFF. HUB (RIGHT)	15.00
5103	2	GREEN TRUED DONUT (F)	8.50	A039	1	HUB (LEFT) (WITH SCREW)	15.00
5113	2	GREEN TRUED DONUT (R)	9.00	A040	2	DRIVE RING	1.50
6075	6	WASHER (COUNTERSUNK ALUMINUM)	4.00	A041	1	DIFF. CONE SET	2.00
6121	10	BODY PIN (S)	2.00	A042	4	AXLE SPACER	5.00
6151	1	SILICONE OIL #500	4.00	A043	1	F1 WING SET (WITH SCREWS)	15.00
6163	1	SERVO TAPE	4.00	A044	1	HPI F1 DECAL (#3)	2.00
6224	8	TAMIYA F-1 TIRE TAPE WIDE	6.25	A046	4	O-RING P3 BLACK	1.00
6225	8	TAMIYA F1 TIRE TAPE NARROW	4.50	A057	1	REAR AXLE (STEEL)	10.00
6228	2	NYLON STRAP	2.00	A062	1	LOWER BRACE (FRP)	10.00
6501	8	DIFF. BALL 1/8"	2.00	A063	1	UPPER BRACE (FRP)	9.00
6625	1	PINION GEAR 25 TOOTH (64 PITCH)	5.99	A074	1	F1 H-03 CHASSIS (FRP)	20.00
6694	1	SPUR GEAR 94 TOOTH (64 PITCH)(W/BALLS)	4.99	A075	1	F1 H-03 CHASSIS BRACE (FRP)	10.00
A001	1	F1 FRONT SUSPENSION SET	8.00	B005	2	BEARING 3/16" x 5/16" FLANGED	13.00
A002	1	STEERING PARTS SET	6.00	B010	2	BEARING 1/4" x 3/8" FLANGED	14.00
A003	1	SHIM/BUSHING PARTS SET	6.50	Z010	1	FRICITION SHOCK SET	8.00
A004	1	REAR SUS. PARTS SET	6.50	Z012	1	SHOCK SPACER	1.50
A005	5	PIVOT BALL SET	6.00	Z120	1	SERVO SAVER SET(WITH SCREW)	5.50
A006	2	PIN 37.5mm	5.00	Z125	14	BALL CUP	5.00
A007	2	KING PIN 29.5mm	5.00	Z126	4	4-40 BALL END	5.00
A008	2	PIN 2 x 31mm	3.50	Z127	4	4-40 LOCK NUT	2.50
A009	2	JOINT PIN (A)	4.50	Z140	2	TURNBUCKLE (B)	7.00
A010	2	TURNBUCKLE (A) 16mm	5.00	Z150	1	ANTENNA PIPE SET	1.00
A011	2	FRONT AXLE (A)	24.00	Z155	1	DIFF. LUBE	2.00
A012	2	SPRING (E)	3.00	Z200	10	E-CLIP 1/8"	1.00
A013	1	ROLL BRACE (GRAPHITE)	12.00	Z201	4	M4 x 25 FLAT HEAD SCREW	2.00
A014	1	SPRING BRACE	4.00	Z202	8	M4 NUT	2.00
A015	1	ALUM. TUBE 18.5mm	1.50	Z203	10	M3 x 6 WASHER	1.00
A016	3	PIVOT BALL (A)	5.00	Z205	6	4-40 x 1/4" FLAT HEAD SCREW	2.00
A017	1	ROLL TOWER	18.00	Z206	4	4-40 x 3/8" FLAT HEAD SCREW	1.00
A018	2	ROLL SPRING (A)	2.00	Z207	6	4-40 x 5/16" BUTTON HEAD SCREW	2.00
A019	2	DAMPENER SPRING	1.00	Z208	4	4-40 x 5/16" BUTTON HEAD SCREW	1.00
A020	4	O-RING P5	1.00	Z209	8	M2 x 10 FLAT HEAD SCREW	2.00
A022	1	F1 H-03 CHASSIS (GRAPHITE)	45.00	Z210	10	2-56 x 5/16" BUTTON HEAD SCREW	2.00
A023	1	F1 H-03 CHASSIS BRACE (GRAPHITE)	16.00	Z211	8	M2 NUT	2.00
A024	3	ALUM. TUBE 25mm	5.00	Z212	6	M3 x 12 BUTTON HEAD SCREW	2.00
A026	1	ANTENNA MOUNT	1.50	Z213	8	8-32 x 1/2" FLAT HEAD SCREW (GREEN)	1.50
A027	1	ALUM. SPACER (D)	1.00	Z214	4	M3 x 8 BUTTON HEAD SCREW	1.00
A028	1	UPPER POD BRACE (GRAPHITE)	16.00	Z218	4	8-32 NYLON NUT	1.50
A029	1	LOWER POD BRACE (GRAPHITE)	19.00	Z220	6	5-40 NYLON NUT	1.50
A030	1	MOTOR MOUNT (RIGHT)	25.00	Z221	10	2-56 x 3/16" BUTTON HEAD SCREW	2.00
A031	1	BULKHEAD (LEFT)	2.50	Z900	1	ALLEN WRENCH SET (3/64", 1.5mm, 3/32")	1.50
A032	1	ROLL BRACE (FRP)	8.00				
A033	2	HEIGHT ADAPTOR #1	1.00				
A034	2	HEIGHT ADAPTOR #2	1.00				
A035	2	SPACER (C) ALUMINUM CONE	2.50				